

Bypass level indicator, heating jacket version, model BNA-J

Bypass chamber and heating jacket pipe from stainless steel

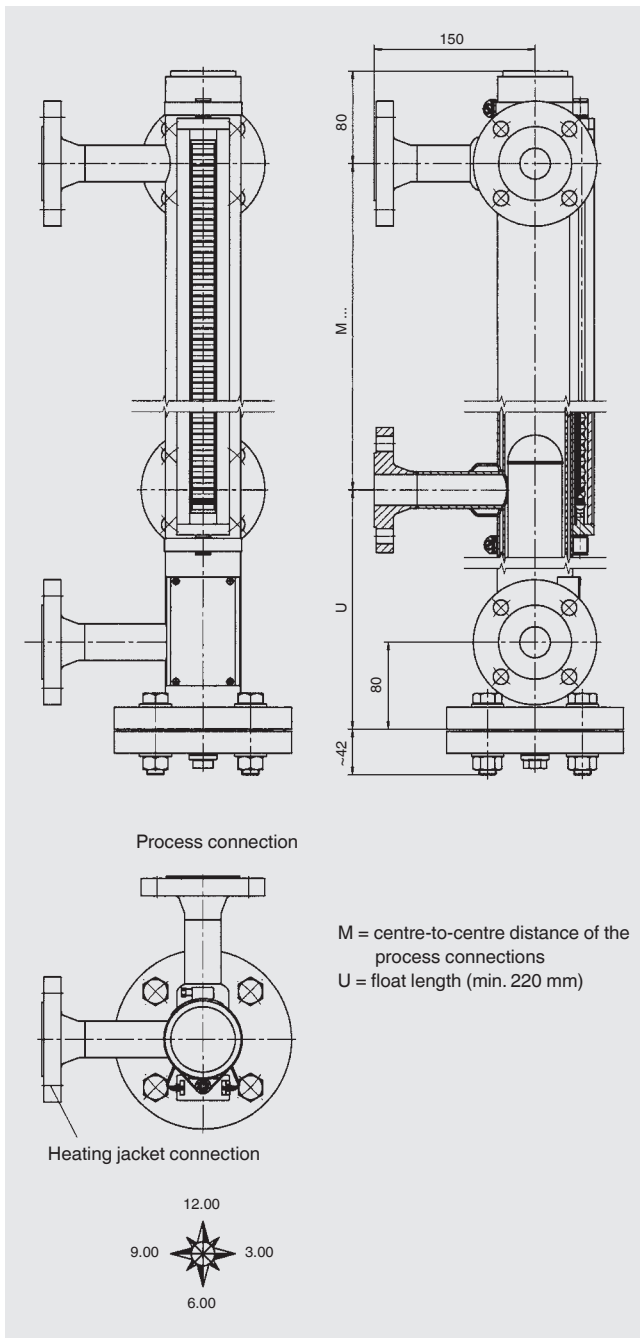

Specifications

Bypass chamber	Ø 60.3 x 2 mm, max. 40 bar Ø 60.3 x 2.77 mm, max. 64 bar
Heating jacket pipe	Ø 70 x 2 mm
Chamber end top	Flat top Options: (see page 14) ■ Vent screw ■ Vent valve ■ Vent flange
Chamber end bottom	Flange connection Options: (see page 14) ■ Drain plug ■ Drain valve ■ Drain flange
Process connections	2 x lateral (options see page 15) Flange EN 1092-1, DN 10 - DN 100, PN 6 - PN 100 Flange DIN, DN 10 - DN 100, PN 6 - PN 100 Flange ANSI B 16.5, 1/2" - 4", class 150 - class 600 Weld stub 1/2" - 1" Threaded bushing G/NPT 1/2" - 1" Threaded nipple G/NPT 1/2" - 1"
Heating jacket connection	Flange EN 1092-1, DN 10 - DN 25, PN 6 - PN 40 Flange DIN, DN 10 - DN 25, PN 6 - PN 40 Flange ANSI B 16.5, 1/2" - 4", class 150 - class 300 Threaded bushing G/NPT 1/2" - 1" Threaded nipple G/NPT 1/2" - 1"
Centre-to-centre distance	Min. 150 mm to max. 6,000 mm (larger distances on request)
Material	Stainless steel 1.4571 with bypass chamber Ø 60.3 x 2 mm (standard version) Stainless steel 1.4404 with bypass chamber Ø 60.3 x 2.77 mm on request
Nominal pressure	Max. 64 bar
Temperature range	-60 ... +450 °C
Float	Cylindrical float, model BFT-H, see data sheet LM 10.02
Magnetic display	Standard version, model BMD-S: < 200 °C High-temperature version, model BMD-F: > 200 °C, see data sheet LM 10.03
Level sensor	Reed sensor, model BLR, see data sheet LM 10.04 Magnetostrictive sensor, model BLM, see data sheet LM 10.05
Magnetic switches	Magnetic switch, model BGU, see data sheet LM 10.06
Approvals	Ex c, GL, GOST-R

Special versions on request